

VZ3.4

Raw Material: Medium Carbon Steel, Heat treated to 8.8 Grade

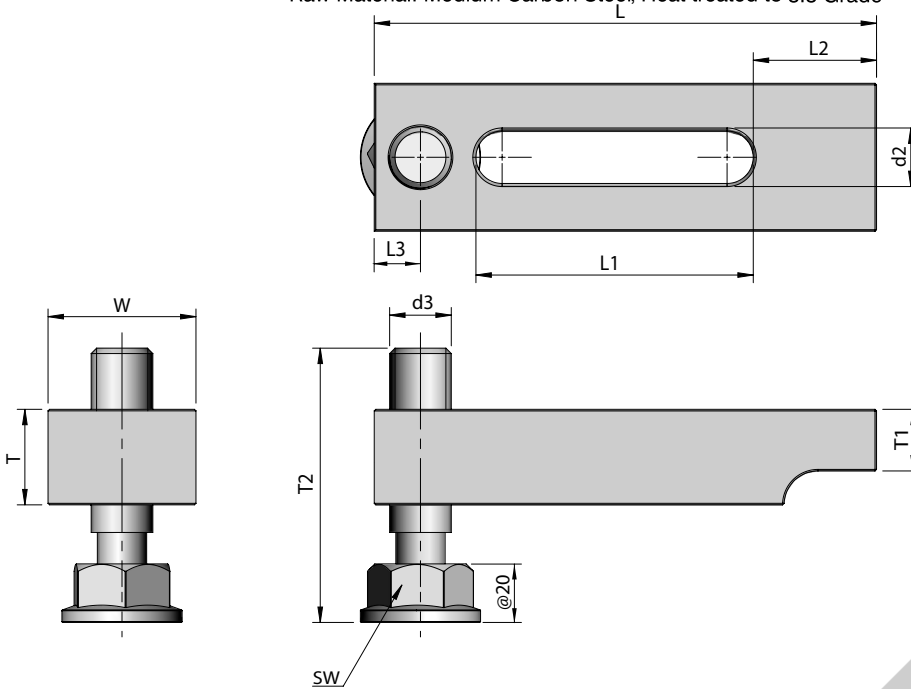

Code	L	L1	L2	L3	W	T	T1	T2	Bolt Size	d2	d3	Stock
VZ3.4/ 001	115	65	20	15	38	24	15	55	M12	14	M16	•
VZ3.4/ 002	115	65	20	15	38	24	15	90	M12	14	M16	•
VZ3.4/ 003	130	70	25	18	48	31	20	60	M16	18	M20	•
VZ3.4/ 004	130	70	25	18	48	31	20	90	M16	18	M20	•
VZ3.4/ 005	160	90	30	20	48	31	20	60	M16	18	M20	•
VZ3.4/ 006	160	90	30	20	48	31	20	90	M16	18	M20	•
VZ3.4/ 007	140	70	35	18	60	38	25	60	M20	22	M24	•
VZ3.4/ 008	140	70	35	18	60	38	25	100	M20	22	M24	•
VZ3.4/ 009	160	90	35	20	60	38	30	60	M20	22	M24	•
VZ3.4/ 010	160	90	35	18	60	45	30	100	M20	22	M24	•
VZ3.4/ 011	200	110	45	22	60	45	30	100	M20	22	M24	•
VZ3.4/ 012	200	105	45	25	78	48	35	100	M24	26	M27	•

✓ - Ex-stock • - Against Order | Ordering Example: Code - Quantity | VZ3.4/ 012 - 4 Pcs

Note: Please select T-Bolt or Stud Bolt and type of nut with suitable size to order flat clamp set. Please refer to Page No. 399, 400, 401, 402