

**VD2.11**

**Through Hardened**  
 Raw Material: 1.2379  
 Hardness: 58 HRC  
**Oilless**  
 2.0492/180HB  
 Max Temp. 200°C

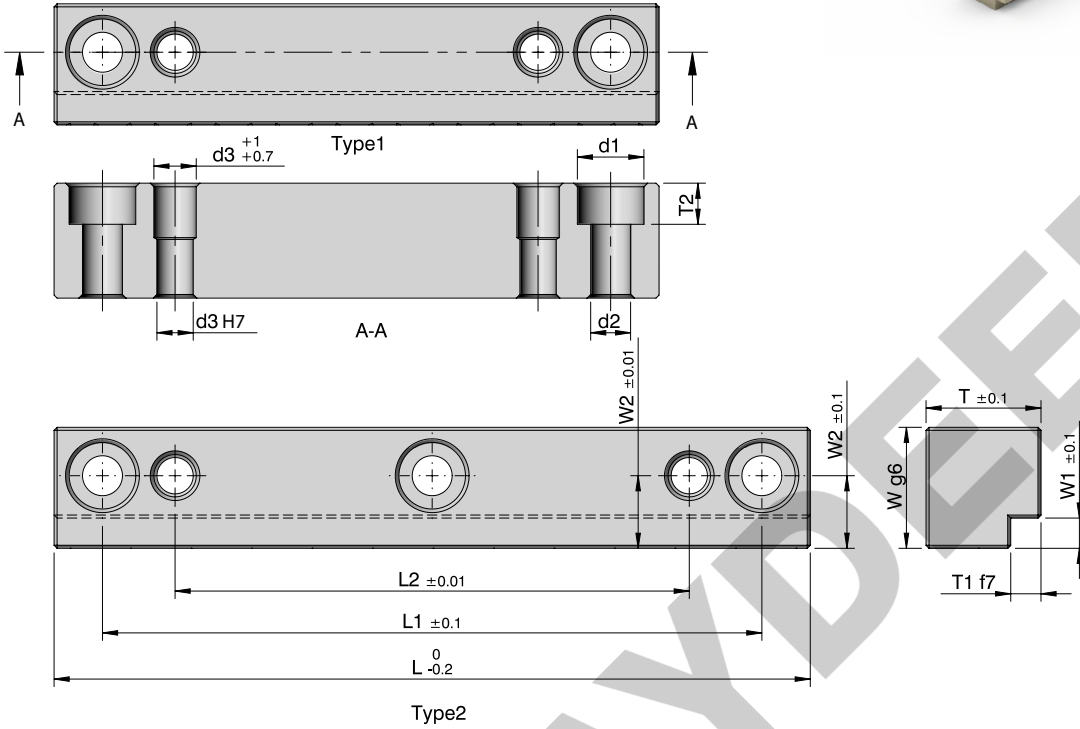

VD

Code		Type	L	L1	L2	W	W1	W2	T	T1	T2	d1	d2	d3	Stock
Steel	Oilless														
VD2.11/001 - S	VD2.11/001 - O	1	50	34	14	16	5	9.5	11	4	5.7	10	5.5	5	•
VD2.11/002 - S	VD2.11/002 - O		71	55	35										•
VD2.11/003 - S	VD2.11/003 - O		90	74	54										•
VD2.11/004 - S	VD2.11/004 - O	1	80	64	40	20	5	12	19	5	6.8	11	6.6	6	•
VD2.11/005 - S	VD2.11/005 - O		100	84	60										•
VD2.11/006 - S	VD2.11/006 - O	2	125	109	85	25	6	15.5	31	6	9	15	9	8	•
VD2.11/007 - S	VD2.11/007 - O	1	100	80	50										•
VD2.11/008 - S	VD2.11/008 - O		125	105	75										•
VD2.11/009 - S	VD2.11/009 - O	2	160	140	110	30	7	18	49	8	11	18	11	10	•
VD2.11/010 - S	VD2.11/010 - O	1	125	95	55										•
VD2.11/011 - S	VD2.11/011 - O		160	130	90										•
VD2.11/012 - S	VD2.11/012 - O	2	200	170	130										•

✓ - Ex-stock • - Against Order | Ordering Example: Code- Quantity | VD2.11/012 - S - 8 Pcs