

VD1.6
Top Insert mounting Type

	Raw Material	Hardness	Surface Treatment
Locking Unit	DH2F	38-42 HRC	Nitrided
Slide Unit	SKD11	58-60 HRC	-
Base	DH2F	38-42 HRC	Nitrided

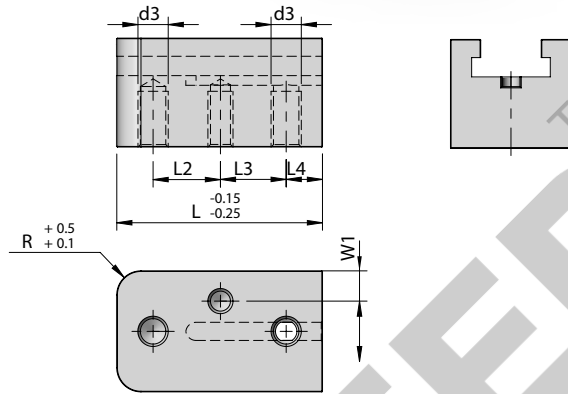

③ Base

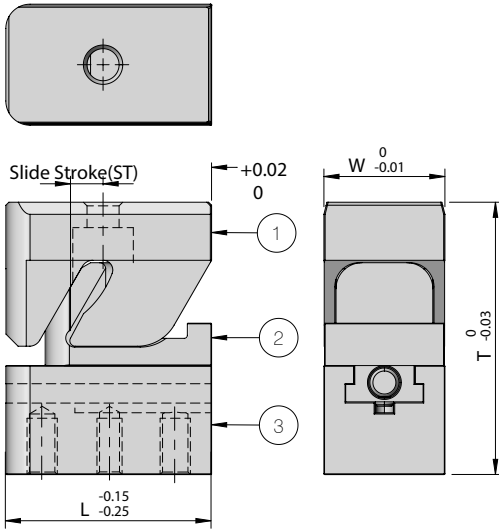
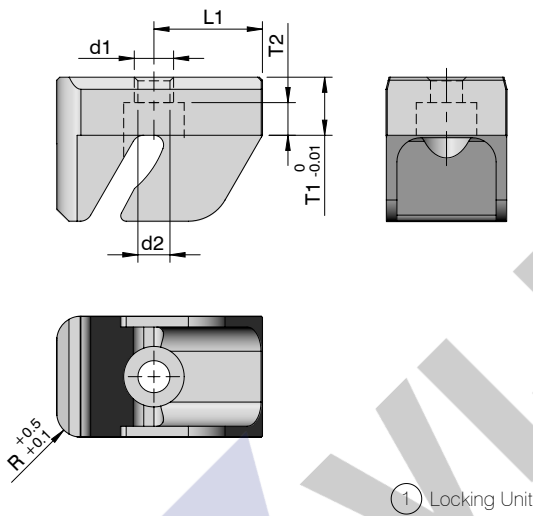

① Locking Unit

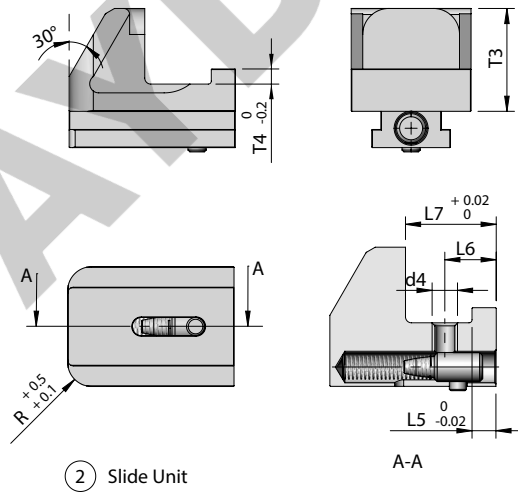

② Slide Unit

Code	Stroke	L	L1	L2	L3	L4	L5	L6	L7	W	W1	T	T1	T2	T3	T4	d1	d2	d3	d4	R	Spring Return	Stock
VD1.6/001	3	20	10	5	5	5	2.5	5	9	12	6	30	8	3.7	10	1.5	M5	4.2	M4	M3	3	-	•
VD1.6/002	3	20	10	5	5	5	2.5	5	9	12	3.5	30	8	3.7	10	1.5	M5	4.2	M4	M3	3	SR	•
VD1.6/003	6	34	18	11	11	6	4	8	15	20	6	45	10	4.7	17	2.5	M6	5.1	M5	M4	4	SR	•
VD1.6/004	10	50	26	17	17	8	5	10	18	32	10	64	15	8.7	25	3	M8	6.8	M6	M5	5	SR	•

✓ - Ex-stock • - Against Order | Ordering Example: Code- Quantity | VD1.6/ 004 - 8 Pcs