

VD1.5
Front Insert mounting Type

	Raw Material	Hardness	Surface Treatment
Locking Unit	DH2F	38-42 HRC	Nitrided
Slide Unit	SKD11	58-60 HRC	-
Base	DH2F	38-42 HRC	Nitrided

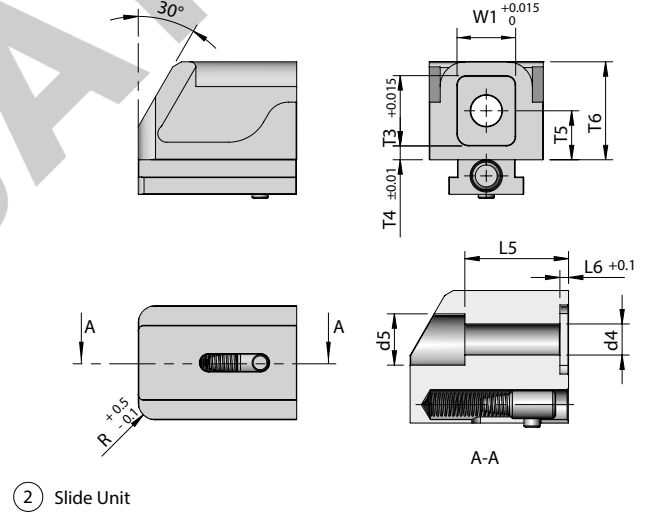
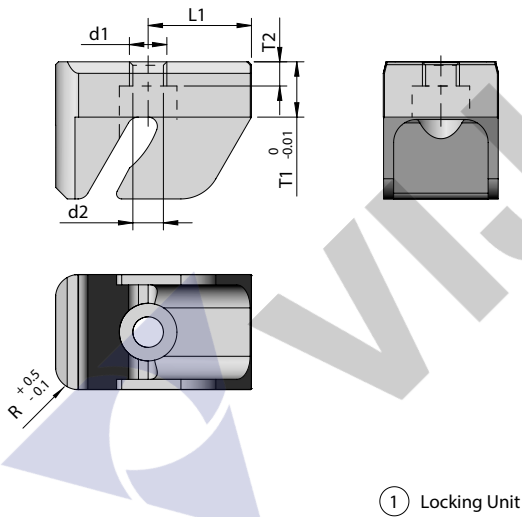
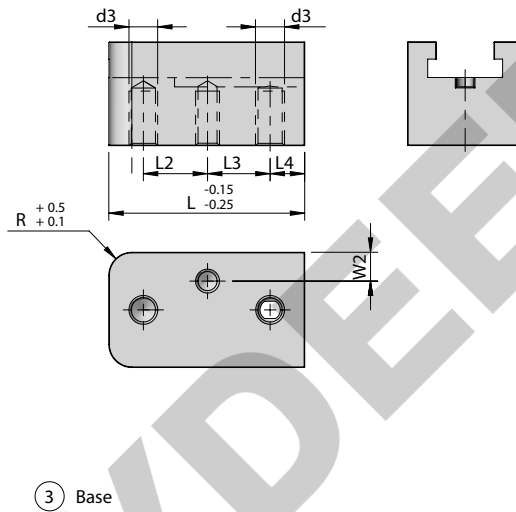
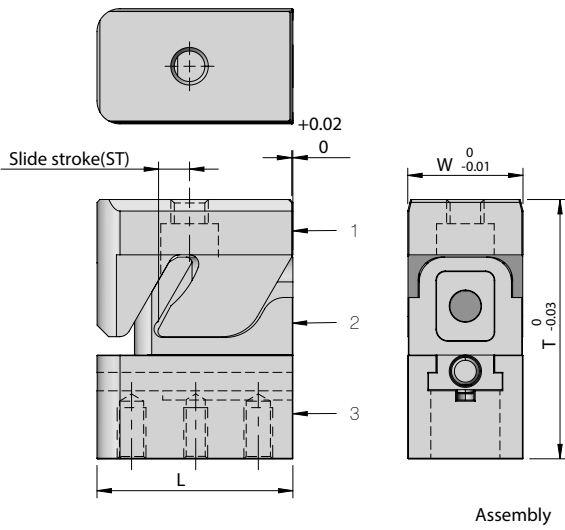

Code	Stroke	L	L1	L2	L3	L4	L5	L6	W	W1	W2	T	T1	T2	T3	T4	T5	T6	d1	d2	d3	d4	d5	R	Spring Return	Stock
VD1.5/ 001	3	20	10	5	5	5	11	1.5	12	5.6	6	30	8	3.7	7	1.5	5	10	M5	4.2	M4	3.3	5.8	3	-	•
VD1.5/ 002	3	20	10	5	5	5	11	1.5	12	5.6	3.5	30	8	3.7	7	1.5	5	10	M5	4.2	M4	3.3	5.8	3	SR	•
VD1.5/ 003	6	34	18	11	11	6	18	1.5	20	10	6	45	10	4.7	12	2.5	8.5	17	M6	5.1	M5	5.4	8.9	4	SR	•
VD1.5/ 004	10	50	26	17	17	8	23	1.7	32	20	10	64	15	8.7	18	3.5	12.5	25	M8	6.8	M6	6.4	10.4	5	SR	•

✓ - Ex-stock • - Against Order | Ordering Example: Code-Quantity | VD1.5/ 004 - 8 Pcs