

VA3.5

Raw Material: OHNS
Hardness: 52-54 HRC

Raw Material: Hot Die Steel (H-11/H-13)
Hardness: Surface Nitrided to 60-62 HRC Core 45-50 HRC

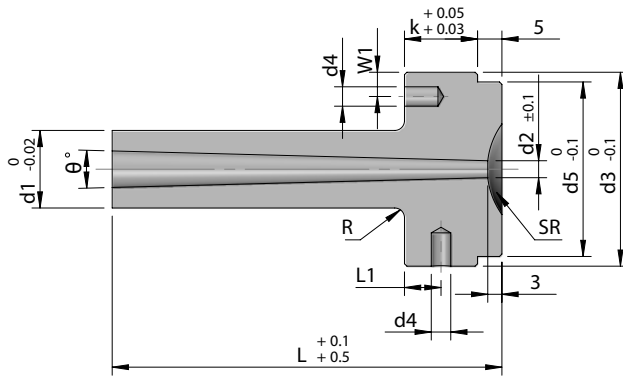

◆ Note: Sizes can be made as per customer's requirement.

Code		d1	d2	d3	d4	d5	L	L1	W1	k	SR	R	θ	Stock
OHNS	H13 (HDS)													

VA3.6

Raw Material: OHNS
Hardness: 52-54 HRC

Raw Material: Hot Die Steel (H-11/H-13)
Hardness: Surface Nitrided to 60-62 HRC Core 45-50 HRC

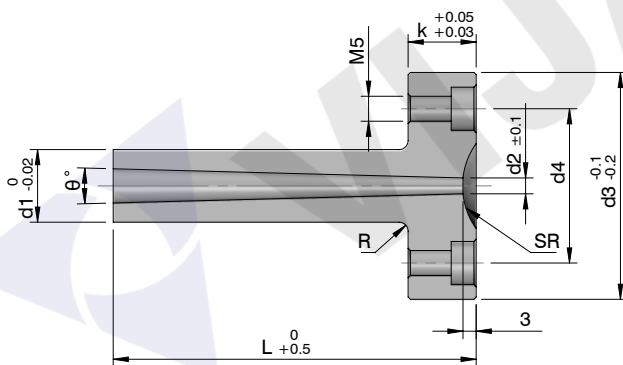

◆ Note: Sizes can be made as per customer's requirement.

Code		d1	d2	d3	d4	L	k	SR	R	θ	Stock
OHNS	H13 (HDS)										