

VA3.3

Raw Material: OHNS
Hardness: 52-54 HRC

Raw Material: Hot Die Steel (H-11/H-13)
Hardness: Surface Nitrided to 60-62 HRC Core 45-50 HRC

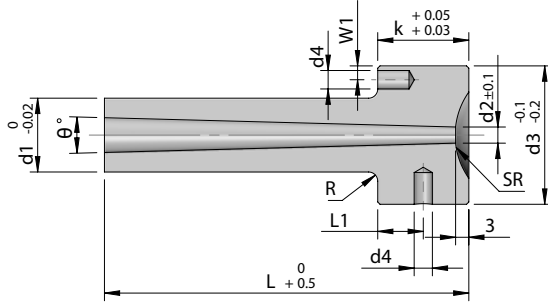

VA

Code		d1	d2	d3	d4	L	L1	W1	k	SR	R	θ	Stock
OHNS	H13 (HDS)												
VA3.3/ 001-C	VA3.3/ 001-H	20	4	35	4	50	10	3.75	20	0	2	3°	●
VA3.3/ 002-C	VA3.3/ 002-H					60							●
VA3.3/ 003-C	VA3.3/ 003-H					70							●
VA3.3/ 004-C	VA3.3/ 004-H					80							●
VA3.3/ 005-C	VA3.3/ 005-H					90							●
VA3.3/ 006-C	VA3.3/ 006-H					100							●
VA3.3/ 007-C	VA3.3/ 007-H					120							●
VA3.3/ 008-C	VA3.3/ 008-H					140							●
VA3.3/ 009-C	VA3.3/ 009-H					160							●
VA3.3/ 010-C	VA3.3/ 010-H					50							20
VA3.3/ 011-C	VA3.3/ 011-H	60	●										
VA3.3/ 012-C	VA3.3/ 012-H	70	●										
VA3.3/ 013-C	VA3.3/ 013-H	80	●										
VA3.3/ 014-C	VA3.3/ 014-H	90	●										
VA3.3/ 015-C	VA3.3/ 015-H	100	●										
VA3.3/ 016-C	VA3.3/ 016-H	120	●										
VA3.3/ 017-C	VA3.3/ 017-H	140	●										
VA3.3/ 018-C	VA3.3/ 018-H	160	●										
VA3.3/ 019-C	VA3.3/ 019-H	50	20	4	35	4	10	3.75	20	16	2	3°	
VA3.3/ 020-C	VA3.3/ 020-H	60											●
VA3.3/ 021-C	VA3.3/ 021-H	70											●
VA3.3/ 022-C	VA3.3/ 022-H	80											●
VA3.3/ 023-C	VA3.3/ 023-H	90											●
VA3.3/ 024-C	VA3.3/ 024-H	100											●
VA3.3/ 025-C	VA3.3/ 025-H	120											●
VA3.3/ 026-C	VA3.3/ 026-H	140											●
VA3.3/ 027-C	VA3.3/ 027-H	160											●
VA3.3/ 028-C	VA3.3/ 028-H	50											20
VA3.3/ 029-C	VA3.3/ 029-H	60	●										
VA3.3/ 030-C	VA3.3/ 030-H	70	●										
VA3.3/ 031-C	VA3.3/ 031-H	80	●										
VA3.3/ 032-C	VA3.3/ 032-H	90	●										
VA3.3/ 033-C	VA3.3/ 033-H	100	●										
VA3.3/ 034-C	VA3.3/ 034-H	120	●										
VA3.3/ 035-C	VA3.3/ 035-H	140	●										
VA3.3/ 036-C	VA3.3/ 036-H	160	●										

✓ - Ex-stock ● - Against Order | Ordering Example: Code - Quantity | VA3.3/ 036-C - 4 Pcs