

**VF3.1
Adjustable**

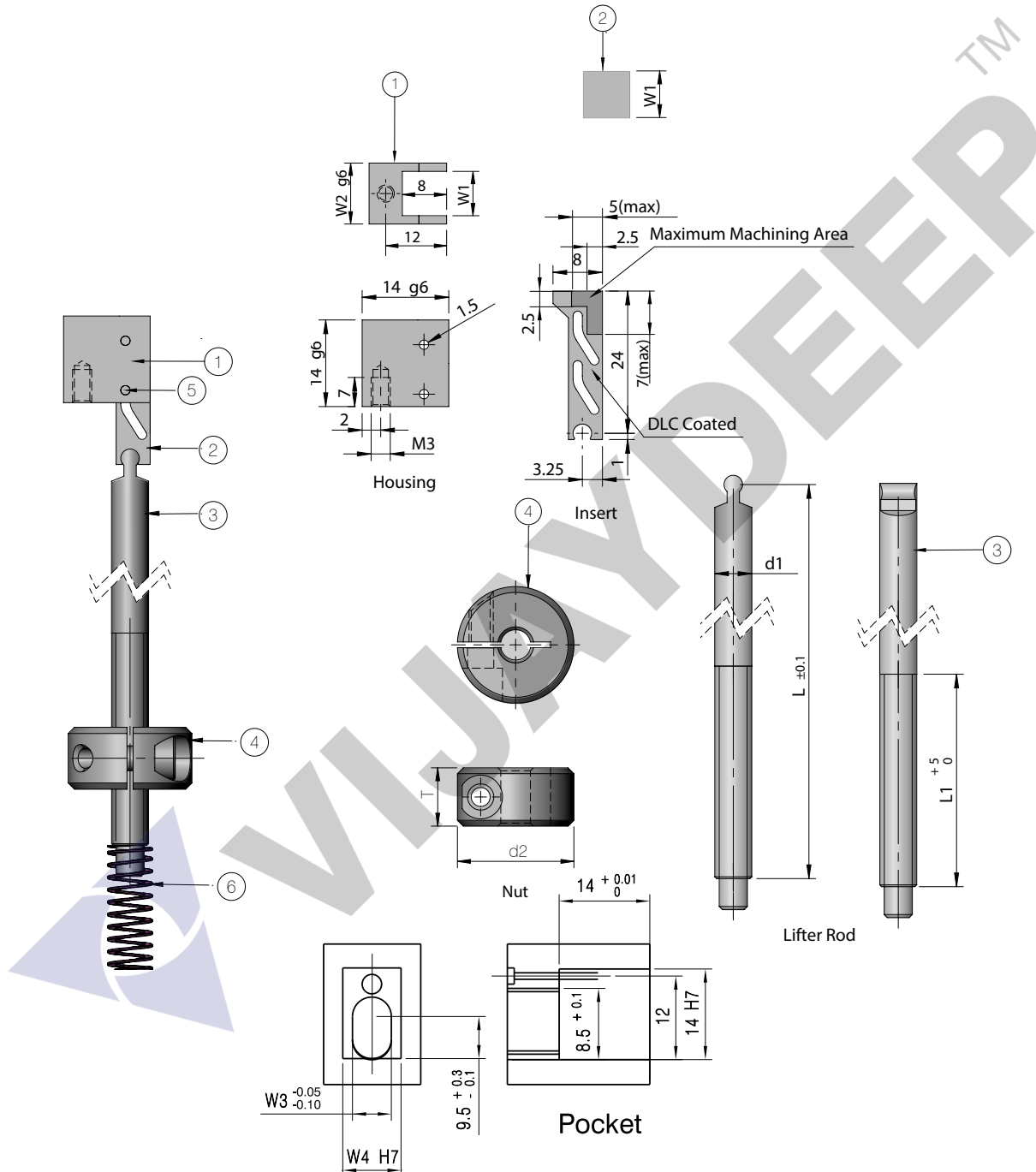

| | Item | Material | Qty. |
|---|---------------------|--------------|------|
| 1 | Housing | SKD 11 | 1 |
| 2 | Insert (DLC Coated) | SKD 61 | 1 |
| 3 | Lifter Rod | SUJ 2 | 1 |
| 4 | Nut | S45 C | 1 |
| 5 | Dowel Pin | SUJ 2 | 2 |
| 6 | Spring | Spring Steel | 1 |



| Code | Housing | | Pocket | | Lifter Rod | | | Nut | | Spring | Guide Pin Tap | Stock |
|-------------------|---------|----|--------|----|------------|---------------------|---------------------|-----|----|---------|---------------|-------|
| | W1 | W2 | W3 | W4 | d1 | L | L1 | d2 | T | | | |
| VF3.1/ 4 x L x L1 | 4 | 7 | 6 | 7 | 6 | Customer to Specify | Customer to Specify | 20 | 10 | Ø6 x 25 | M3 | • |
| VF3.1/ 6 x L x L1 | 6 | 9 | | 9 | | | | | | | | • |
| VF3.1/ 8 x L x L1 | 8 | 11 | | 11 | | | | | | | | • |

✓ - Ex-stock • - Against Order | Ordering Example: Code - Quantity | VF3.1/ 8 x L x L1 - 5 Pcs

VF