

VD2.12

Through Hardened
Raw Material: 1.2379
Hardness: 58 HRC
Oilless
2.0492/180HB
Max Temp. 200°C

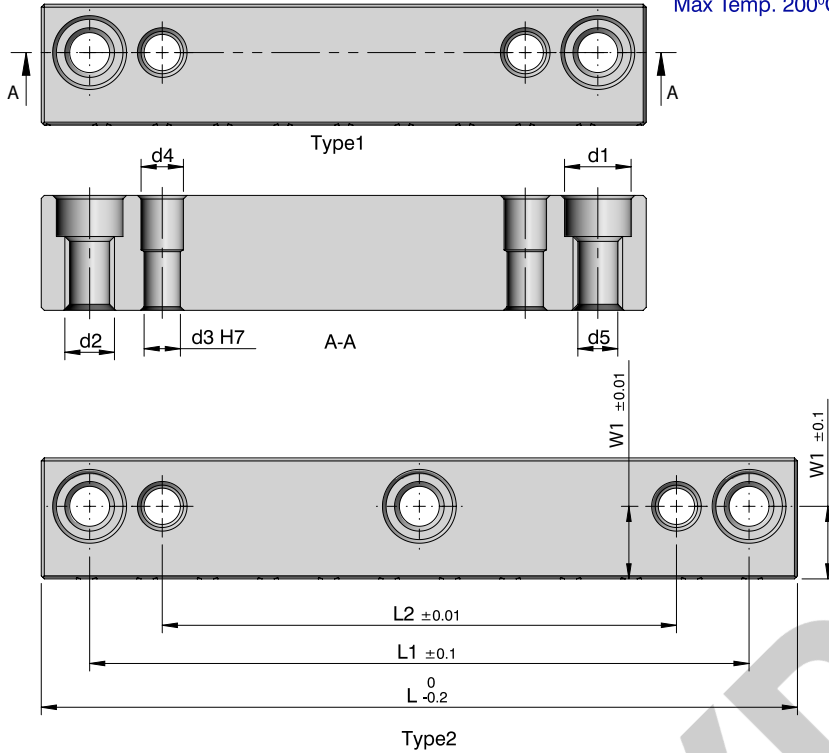

Code		Type	L	L1	L2	W	W1	T	d1	d2	d3	d4	d5	Stock																
Steel	Oilless																													
VD2.12/ 001 - S	VD2.12/ 001 - O	1	50	34	14	16	9.5	7	10	M6	5	-	5.3	•																
VD2.12/ 002 - S	VD2.12/ 002 - O	2	71	55	35									11	•															
VD2.12/ 003 - S	VD2.12/ 003 - O		90	74	54										•															
VD2.12/ 004 - S	VD2.12/ 004 - O	1	50	34	14			11						14	11	M8	6	7	6.8	•										
VD2.12/ 005 - S	VD2.12/ 005 - O	2	71	55	35															•										
VD2.12/ 006 - S	VD2.12/ 006 - O		90	74	54															•										
VD2.12/ 007 - S	VD2.12/ 007 - O	1	80	64	40	20	12	19	11	M8	6	7	6.8							•										
VD2.12/ 008 - S	VD2.12/ 008 - O	2	100	84	60															•										
VD2.12/ 009 - S	VD2.12/ 009 - O		125	109	85															•										
VD2.12/ 010 - S	VD2.12/ 010 - O	1	80	64	40			25						15.5	25	15	M10	8	9	8.5	•									
VD2.12/ 011 - S	VD2.12/ 011 - O	2	100	84	60																•									
VD2.12/ 012 - S	VD2.12/ 012 - O		125	109	85																•									
VD2.12/ 013 - S	VD2.12/ 013 - O	1	100	80	50	30	18		33	18	M12	10	11		10.5						•									
VD2.12/ 014 - S	VD2.12/ 014 - O		125	105	75																•									
VD2.12/ 015 - S	VD2.12/ 015 - O		2	160	140																110	41	54	18	M12	10	11	10.5	•	
VD2.12/ 016 - S	VD2.12/ 016 - O	1	100	80	50			•																						
VD2.12/ 017 - S	VD2.12/ 017 - O		125	105	75			•																						
VD2.12/ 018 - S	VD2.12/ 018 - O	2	160	140	110			30	18					41		18	M12	10	11	10.5	•									
VD2.12/ 019 - S	VD2.12/ 019 - O	1	125	95	55	54	18			M12	10	11	10.5		•															
VD2.12/ 020 - S	VD2.12/ 020 - O		160	130	90										•															
VD2.12/ 021 - S	VD2.12/ 021 - O	2	200	170	130									54	18						M12	10	11	10.5	•					
VD2.12/ 022 - S	VD2.12/ 022 - O	1	125	95	55	54																			18	M12	10	11	10.5	•
VD2.12/ 023 - S	VD2.12/ 023 - O		160	130	90																									•
VD2.12/ 024 - S	VD2.12/ 024 - O	2	200	170	130			•																						

✓ - Ex-stock • - Against Order | Ordering Example: Code- Quantity | VD2.12/ 024 - S - 8 Pcs