

VA3.4

Raw Material: OHNS
Hardness: 52-54 HRC

Raw Material: Hot Die Steel (H-11/H-13)
Hardness: Surface Nitrided to 60-62 HRC Core 45-50 HRC

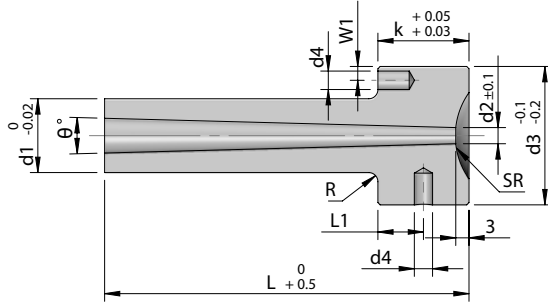

VA

Code		d1	d2	d3	d4	L	L1	W1	k	SR	R	θ	Stock
OHNS	H13 (HDS)												
VA3.4/ 001-C	VA3.4/ 001-H	24	5	40	4	60	10	4	20	0	2	3°	●
VA3.4/ 002-C	VA3.4/ 002-H					70							●
VA3.4/ 003-C	VA3.4/ 003-H					80							●
VA3.4/ 004-C	VA3.4/ 004-H					90							●
VA3.4/ 005-C	VA3.4/ 005-H					100							●
VA3.4/ 006-C	VA3.4/ 006-H					120							●
VA3.4/ 007-C	VA3.4/ 007-H					140							●
VA3.4/ 008-C	VA3.4/ 008-H					160							●
VA3.4/ 009-C	VA3.4/ 009-H					180							●
VA3.4/ 010-C	VA3.4/ 010-H	24	5	40	4	60	10	4	20	12	2	2°	●
VA3.4/ 011-C	VA3.4/ 011-H					70							●
VA3.4/ 012-C	VA3.4/ 012-H					80							●
VA3.4/ 013-C	VA3.4/ 013-H					90							●
VA3.4/ 014-C	VA3.4/ 014-H					100							●
VA3.4/ 015-C	VA3.4/ 015-H					120							●
VA3.4/ 016-C	VA3.4/ 016-H					140							●
VA3.4/ 017-C	VA3.4/ 017-H					160							●
VA3.4/ 018-C	VA3.4/ 018-H					180							●
VA3.4/ 019-C	VA3.4/ 019-H	24	5	40	4	60	10	4	20	16	2	3°	●
VA3.4/ 020-C	VA3.4/ 020-H					70							●
VA3.4/ 021-C	VA3.4/ 021-H					80							●
VA3.4/ 022-C	VA3.4/ 022-H					90							●
VA3.4/ 023-C	VA3.4/ 023-H					100							●
VA3.4/ 024-C	VA3.4/ 024-H					120							●
VA3.4/ 025-C	VA3.4/ 025-H					140							●
VA3.4/ 026-C	VA3.4/ 026-H					160							●
VA3.4/ 027-C	VA3.4/ 027-H					180							●
VA3.4/ 028-C	VA3.4/ 028-H	24	5	40	4	60	10	4	20	22	2	2°	●
VA3.4/ 029-C	VA3.4/ 029-H					70							●
VA3.4/ 030-C	VA3.4/ 030-H					80							●
VA3.4/ 031-C	VA3.4/ 031-H					90							●
VA3.4/ 032-C	VA3.4/ 032-H					100							●
VA3.4/ 033-C	VA3.4/ 033-H					120							●
VA3.4/ 034-C	VA3.4/ 034-H					140							●
VA3.4/ 035-C	VA3.4/ 035-H					160							●
VA3.4/ 036-C	VA3.4/ 036-H					180							●