

**VA3.1**

Raw Material: OHNS  
Hardness: 52-54 HRC

Raw Material:  
Hot Die Steel (H-11/H-13)  
Hardness: Surface Nitrided to  
60-62 HRC Core 45-50 HRC

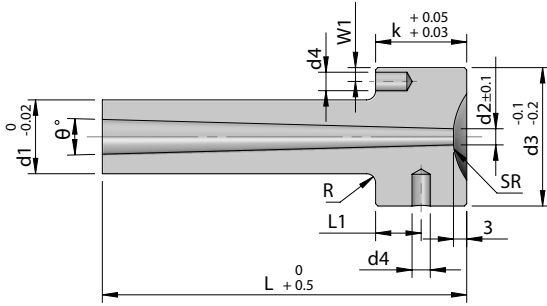

Code		d1	d2	d3	d4	L	L1	W1	k	SR	R	θ	Stock
OHNS	H13 (HDS) Nitrided												
VA3.1/ 001-C	VA3.1/ 001-H	12	3	25	3	40	7.5	3.25	15	0	1.5	2°	●
VA3.1/ 002-C	VA3.1/ 002-H					50							●
VA3.1/ 003-C	VA3.1/ 003-H					60							●
VA3.1/ 004-C	VA3.1/ 004-H					70							●
VA3.1/ 005-C	VA3.1/ 005-H					80							●
VA3.1/ 006-C	VA3.1/ 006-H	12	3	25	3	40	7.5	3.25	15	0	1.5	3°	●
VA3.1/ 007-C	VA3.1/ 007-H					50							●
VA3.1/ 008-C	VA3.1/ 008-H					60							●
VA3.1/ 009-C	VA3.1/ 009-H					70							●
VA3.1/ 010-C	VA3.1/ 010-H					80							●
VA3.1/ 011-C	VA3.1/ 011-H	12	3	25	3	40	7.5	3.25	15	12	1.5	2°	●
VA3.1/ 012-C	VA3.1/ 012-H					50							●
VA3.1/ 013-C	VA3.1/ 013-H					60							●
VA3.1/ 014-C	VA3.1/ 014-H					70							●
VA3.1/ 015-C	VA3.1/ 015-H					80							●
VA3.1/ 016-C	VA3.1/ 016-H	12	3	25	3	40	7.5	3.25	15	12	1.5	3°	●
VA3.1/ 017-C	VA3.1/ 017-H					50							●
VA3.1/ 018-C	VA3.1/ 018-H					60							●
VA3.1/ 019-C	VA3.1/ 019-H					70							●
VA3.1/ 020-C	VA3.1/ 020-H					80							●
VA3.1/ 021-C	VA3.1/ 021-H	12	3	25	3	40	7.5	3.25	15	16	1.5	2°	●
VA3.1/ 022-C	VA3.1/ 022-H					50							●
VA3.1/ 023-C	VA3.1/ 023-H					60							●
VA3.1/ 024-C	VA3.1/ 024-H					70							●
VA3.1/ 025-C	VA3.1/ 025-H					80							●
VA3.1/ 026-C	VA3.1/ 026-H	12	3	25	3	40	7.5	3.25	15	16	1.5	3°	●
VA3.1/ 027-C	VA3.1/ 027-H					50							●
VA3.1/ 028-C	VA3.1/ 028-H					60							●
VA3.1/ 029-C	VA3.1/ 029-H					70							●
VA3.1/ 030-C	VA3.1/ 030-H					80							●
VA3.1/ 031-C	VA3.1/ 031-H	12	3	25	3	40	7.5	3.25	15	22	1.5	2°	●
VA3.1/ 032-C	VA3.1/ 032-H					50							●
VA3.1/ 033-C	VA3.1/ 033-H					60							●
VA3.1/ 034-C	VA3.1/ 034-H					70							●
VA3.1/ 035-C	VA3.1/ 035-H					80							●
VA3.1/ 036-C	VA3.1/ 036-H	12	3	25	3	40	7.5	3.25	15	22	1.5	3°	●
VA3.1/ 037-C	VA3.1/ 037-H					50							●
VA3.1/ 038-C	VA3.1/ 038-H					60							●
VA3.1/ 039-C	VA3.1/ 039-H					70							●
VA3.1/ 040-C	VA3.1/ 040-H					80							●

✓ - Ex-stock ● - Against Order | Ordering Example: Code - Quantity | VA3.1/ 040-C - 4 Pcs

VA